

LT5805A

2.4G无线射频通讯芯片

芯片特点

- ARM® Cortex™ M0+的CPU核
内置24Kbytes Flash, 3Kbytes SRAM
最高24MHz工作频率
- 带有PWM, ADC, UART, SPI, IIC, Beep外设
- 2个16位定时器+1个24位滴答定时器
- 独立看门狗定时器 (IWDG)
- 1个LPTIM低功耗定时器
- 支持在线调试
- 支持蓝牙广播收发, 支持跳频
- 支持无线烧录
- 最大发射功率7dBm, 支持可调
- 四档可变速率: 1Mbps/250Kbps/125Kbps/62.5Kbps
- 支持24M单端晶体
- 空中传输距离达50米或以上
- 15个功能自定义管脚



芯片简介

LT5805A是一款低成本, 高集成度的2.4GHz SOC的无线收发芯片, 片上集成发射机, 接收机, 频率综合器, GFSK 调制解调器和低功耗的MCU。发射机支持功率可调, 接收机采用数字扩展通信机制, 在复杂环境和强干扰条件下, 可以达到优良的收发性能。传输GFSK信号, 发射功率最大可以到+7dBm。接收机采用低中频结构, 接收灵敏度可以达到-85dBm@1bps。

LT5805A片上的MCU功耗低, 可唤醒, 有24K程序空间, 3K数据空间, 支持C/C++/ASM语言编程, 支持Keil MDK, IAR EWARM等开发环境, 同时提供完整的仿真和烧录器, 方便客户使用。发射机可实现无按键自动休眠 (工作电流小于10uA), 芯片最低工作电压可以到2.4V。

LT5805A在系统应用上, 只需少数外围被动器件。单面板就可以保证功能和性能, 支持33mm导线天线大大降低了系统方案的外围成本。

芯片采用TSSOP20脚的封装, 符合RoHS 标准。

典型应用

- BLE电子标签
- 无线遥控
- 智能家居
- 工业和商用近距离通信
- 机器间相互通信

1.封装管脚顺序:

1	XTAL	LT5805A_TSSOP20	ANT	20
2	PB4		ANTb	19
3	PB3		VSS	18
4	PB2		VDD	17
5	PB1		PB6	16
6	PB0		PB7	15
7	PA1		PC0	14
8	PA2		PA7	13
9	PA3		PA6	12
10	PA4		PA5	11

2. 管脚描述

Pin No	Pin Name	Type	Description
1	XTAL	A I	晶体振荡器输入脚
2	PB4	I O	USART_TX I2C_SDA TIM1_BKIN
3	PB3	I O	USART_CK I2C_SCL TIM1_ETR CMP1_OUT
4	PB2	I O	SPI_SCK USART_CTS TIM1_CH1N TIM1_CH3
5	PB1	I O	USART_RTS ADC_IN0 TIM1_CH2N CMP1_INP TIM1_CH4 CMP1_INM MCO
6	PB0	I O	SPI_SCK ADC_IN7 USART_CK CMP1_INM TIM1_CH2 TIM1_CH3N
7	PA1	I O	SPI_MISO TIM1_CH2
8	PA2 (SWCLK)	I O	USART_RX I2C_SCL SWCLK TIM1_CH4 CMP2_OUT
9	PA3	I O	USART_TX ADC_IN1 CMP2_INP TIM1_CH2 CMP2_INM
10	PA4	I O	USART_RX ADC_IN2 TIM1_CH3 CMP2_INM

			TIM14_CH1
11	PA5	I/O	USART_CK TIM1_CH1 TIM14_CH1
12	PA6	I/O	SPI_NSS ADC_IN3 USART_TX External_clock_in EVENTOUT
13	PA7	I/O	SPI_MOSI ADC_IN4 USART_TX USART_RX TIM1_CH4 MCO
14	PC0	I/O	SWDIO NRST TIM1_CH1N ADC_IN5 EVENTOUT
15	PB7	I/O	SPI_MOSI OSCOUT TIM14_CH1
16	PB6 (SWDIO)	I/O	SPI_MISO ADC_IN6 USART_TX I2C_SDA SWDIO
17	VDD (烧录PIN)	Power	Digital power supply
18	VSS (烧录PIN)	VSS	Ground
19	ANTb	Balanced RF	射频输入输出b (通过0R电阻接地)
20	ANT	Balanced RF	射频输入输出

3.IC内部数字接口

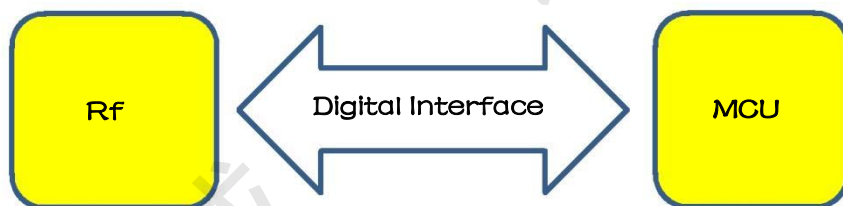

RF数据输入输出	IIC_DAT	↔	PB5	功能脚
RF时钟信号	IIC_CLK	↔	PA0	功能脚

4.LT5805A参考原理图

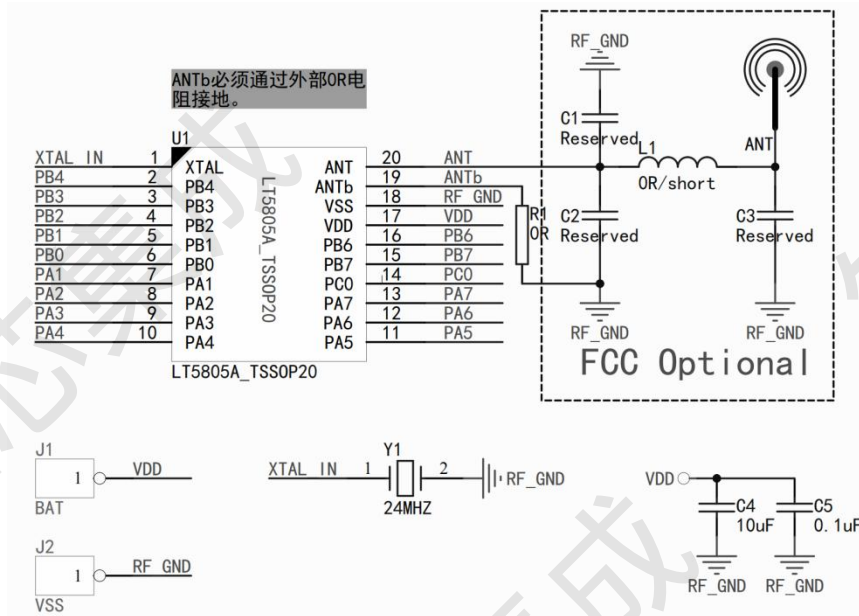

5. 封装尺寸参数

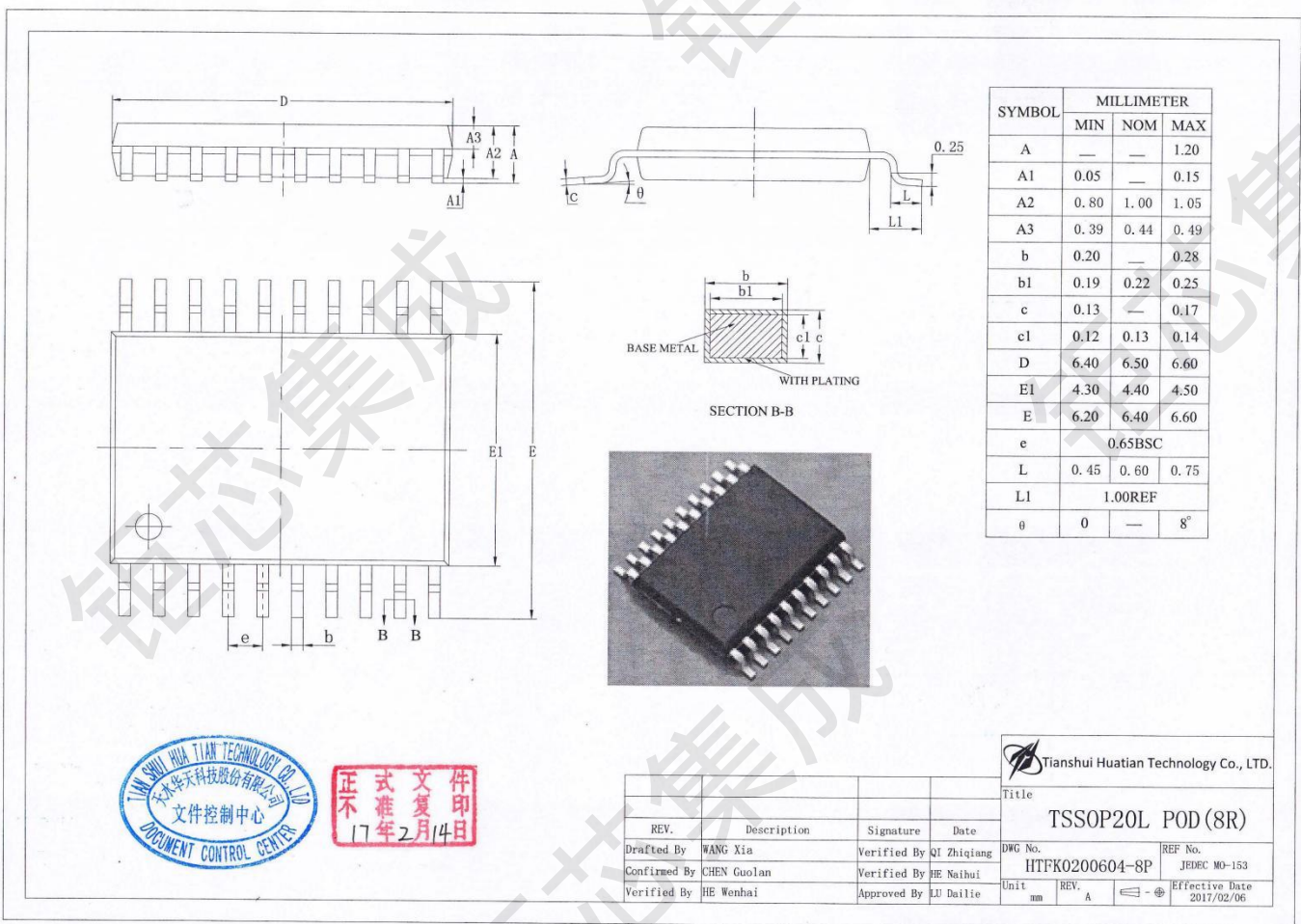

极限值

Table 1. 射频极限值

Parameter	Symbol	MIN	TYP	MAX	Unit
工作温度.	T_{OP}	-10		+85	°C
存储温度.	$T_{STORAGE}$	-55		+125	°C
工作电压	V_{IN_MAX}	2.4	3.3	+5.0	VDC
I/O电压	V_{OTHER}	-0.3		+5.0	
输入射频信号强度	P_{IN}			+7	dBm

Notes:

1. 极限值表示芯片在超出此条件工作时，可能会损坏。芯片在建议工作值范围内功能正常。
2. 芯片对静电比较敏感，在运输和存储时，最好使用防静电设备，用机器或手工焊接时要有良好的接地。

射频电气特性

Table 1. 电气特性

下面的电气特性都是在 TA = 25 C, LDO_VDD= VDD_IO = 3.3 VDC条件下得到的。

Parameter	Symbol	MIN	TYP	MAX	Units	Test Condition and Notes
工作电压						
直流工作电压		2.4		5.0	VDC	Input to VDD_IO and LDO_VDD pins.
工作电流						
TX工作电流	IDD_TXH		24		mA	POUT =2dBm
	IDD_TXL		15		mA	POUT = low power setting
RX工作电流	IDD_RX		18		mA	
Idle mode工作电流	IDD_IDLE1		1.4		mA	Configured for BRCLK output running.
	IDD_IDLE2		1.1		mA	Configured for BRCLK output OFF.
Sleep mode工作电流	IDD_SLP		10		uA	
数字输入						
高电平电压	VIH	0.8		1.2	V	
		VDD_IN		VDD_IN		
低电平电压	VIL	0		0.8	V	
输入电容	C_IN			10	pF	
输入漏电	I_LEAK_IN			10	uA	
数字输出						
高电平电压	VOH	0.8		VDD_IN	V	
		VDD_IN				
低电平电压	VOL			0.4	V	
输出电容	C_OUT			10	pF	
输出漏电	I_LEAK_OUT			10	uA	
I2C电平边沿时间	T_RISE_OUT			5	nS	
时钟信号						
I2C时钟沿上升下降时间	Tr_spi			25	nS	Requirement for error-free register reading, writing.
I2C时钟速度	F_SPI	0	2		MHz	
收发器特性						
工作频率	F_OP	2400		2482	MHz	

天线端口差异 (Z0=50Ω)	VSWR_I		<2:1		VSWR	Receive mode.
	VSWR_0		<2:1		VSWR	Transmit mode.

Parameter	Symbol	MIN	TYP	MAX	Unis	Test Condition and Notes
<i>Receive Section</i>						Measured using 50 Ohm balun. For BER ≤ 0.1%:
接收灵敏度			-87		dBm	1Mbps
			-90		dBm	250Kbps
			-93		dBm	125Kbps
			-98		dBm	62.5Kbps
最大输入功率		-20	1		dBm	
数据率	Ts		1		us	
抗干扰特性						For BER ≤ 0.1%
同频干扰	CI_cochannel		+9		dB	-60 dBm desired signal.
1MHz相邻信号干扰	CI_1		+6		dB	-60 dBm desired signal.
2MHz相邻信号干扰	CI_2		-12		dB	-60 dBm desired signal.
3MHz相邻信号干扰	CI_3		-24		dB	-67 dBm desired signal.
带外干扰	OBB_1	-10			dBm	30 MHz to 2000 MHz
	OBB_2	-27			dBm	2000 MHz to 2400 MHz
	OBB_3	-27			dBm	2500 MHz to 3000 MHz
	OBB_4	-10			dBm	3000 MHz to 12.75 GHz
						Meas. with ACX BF2520 ceramic filter 2 on ant. pin. Desired sig. -67 dBm, BER ≤ 0.1%.
<i>Transmit Section</i>						Measured using 50 Ohm balun3:
发射功率	PAV			6		POUT= maximum output power Reg09=0x4800
			2	10	dBm	POUT = nominal output power, Reg09=0x6030
		-17				POUT=minimum output power, Reg09=1FC0
二次谐波			-50		dBm	Conducted to ANT pin.
三次谐波			-50		dBm	Conducted to ANT pin.
调制特性						
最大频偏	00001111 pattern	Δf1avg	280		kHz	
	01010101 pattern	Δf2max	225		kHz	
带内辐射						
2MHz频偏	IBS_2			-40	dBm	
>3MHz频偏	IBS_3			-60	dBm	

带外辐射	OBS_0_1		< -60	-36	dBm	30 MHz ~ 1 GHz
	OBS_0_2		-45	-30	dBm	1 GHz ~ 12.75 GHz, excludes desired signal and harmonics.
	OBS_0_3		< -60	-47	dBm	1.8 GHz ~ 1.9 GHz
	OBS_0_4		< -65	-47	dBm	5.15 GHz ~ 5.3 GHz

Note:

- 测试是在2460MHz频率下进行，干扰信号以1MHz间隔测试。同时因为干扰信号的谐波会影响性能，所以要对其进行良好的滤波。
- 在一些应用中，天线前端会加上滤波器，或者受到天线有效带宽的限制。

Parameter	Symbol	MIN	TYP	MAX	Unit	Test Condition and Notes	
<i>射频VCO和PLL</i>							
PLL锁定范围	FLOCK	2366		2516	MHz		
发射接收机频偏			—		ppm	Same as XTAL pins frequency tolerance	
信道宽度			1		MHz		
单边带相位噪声			≤ -95		dBc/H z	550kHz offset	
			≤ -115		dBc/H z	2MHz offset	
晶体频率			24.00 0		MHz	Designed for 24 MHz crystal reference freq.	
芯片内部晶体调节范围			±20		ppm	See Register 27 description. Amount of pull depends on crystal spec. and operating point.	
PLL稳定时间	THOP		75	150	uS	Settle to within 30 kHz of final value.	
辐射	OBS_1		< -75	-57	dBm	30 MHz ~ 1 GHz	IDLE state, Synthesizer and VCO ON.
	OBS_2		-68	-47	dBm	1 GHz ~ 12.75 GHz	
<i>LDO 电压</i>							
压降范围	Vdo		0.17	0.5	V	Measured during Receive state	